

This article was downloaded by:

On: 22 January 2011

Access details: *Access Details: Free Access*

Publisher *Taylor & Francis*

Informa Ltd Registered in England and Wales Registered Number: 1072954 Registered office: Mortimer House, 37-41 Mortimer Street, London W1T 3JH, UK



The Journal of Adhesion

Publication details, including instructions for authors and subscription information:

<http://www.informaworld.com/smpp/title~content=t713453635>

Ultimate Tensile Stress over a Zone: A New Failure Criterion for Adhesive Joints

J. D. Clark^a; I. J. McGregor^a

^a Banbury Laboratory, Alcan International Ltd., Banbury, Oxon, United Kingdom

To cite this Article Clark, J. D. and McGregor, I. J.(1993) 'Ultimate Tensile Stress over a Zone: A New Failure Criterion for Adhesive Joints', The Journal of Adhesion, 42: 4, 227 – 245

To link to this Article: DOI: 10.1080/00218469308026578

URL: <http://dx.doi.org/10.1080/00218469308026578>

PLEASE SCROLL DOWN FOR ARTICLE

Full terms and conditions of use: <http://www.informaworld.com/terms-and-conditions-of-access.pdf>

This article may be used for research, teaching and private study purposes. Any substantial or systematic reproduction, re-distribution, re-selling, loan or sub-licensing, systematic supply or distribution in any form to anyone is expressly forbidden.

The publisher does not give any warranty express or implied or make any representation that the contents will be complete or accurate or up to date. The accuracy of any instructions, formulae and drug doses should be independently verified with primary sources. The publisher shall not be liable for any loss, actions, claims, proceedings, demand or costs or damages whatsoever or howsoever caused arising directly or indirectly in connection with or arising out of the use of this material.

Ultimate Tensile Stress over a Zone: A New Failure Criterion for Adhesive Joints

J. D. CLARK and I. J. MCGREGOR

Alcan International Ltd., Banbury Laboratory, Southam Rd., Banbury, Oxon, OX16 7SP, United Kingdom

(Received November 10, 1992; in final form March 24, 1993)

The objective of this work was to develop a criterion for predicting the static strength of adhesively-bonded joints. Although there is a large body of literature on this subject, no satisfactory criterion has been proposed in any publication to date. To obtain a criterion, finite element models of widely differing joint geometries were developed, in which the stresses in the adhesive bonds were calculated in great detail. These were then compared with test measurements. After examining two toughened epoxy adhesives, the authors have developed a failure criterion that predicts failure loads to within approximately 15% of measured values. This is: that the maximum principal stress must exceed the ultimate tensile stress of the adhesive material over a finite zone normal to the direction of maximum principal stress. The size of this zone is a property of the adhesive that can be determined from a combination of analysis and test.

KEY WORDS adhesive; strength; failure criterion; finite element; double strap joint; single-lap joint; T-peel joint; rubber-toughened epoxy adhesives; locus of failure.

1. INTRODUCTION

The purpose of this paper is to report the first successful prediction of the static strength of stressed adhesive bonds in different joint geometries, using a single failure criterion. A literature survey is presented showing that no other single method has been able to predict the failure loads in such a variety of joints.

The criterion presented here is that the ultimate tensile stress (UTS) of the adhesive material must be exceeded not just at a point, but over a zone of finite size, and that the zone size is independent of joint geometry. The zone over which the maximum principal stress exceeds the UTS will be referred to as the UTS zone. The criterion has been developed for cohesive failure in the adhesive of bonded joints.

It is shown that this is the case for three joints—single-lap, double strap and T-peel (also sometimes called a coach joint), using two different single-part, rubber-toughened epoxy adhesives which contain inorganic filler particles. Examples of these joints are shown in Figures 1 to 3.

The approach taken was to construct detailed finite element models of the joints and to compare the stress patterns in the adhesive with measured failure loads. By

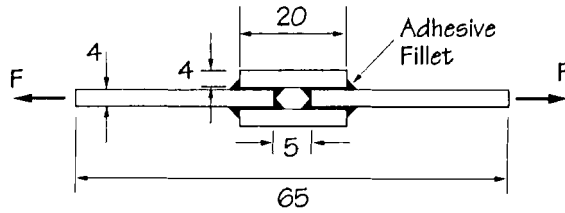

Dimensions in mm
 Bondline Thickness = 0.2mm
 Specimen Width = 12mm
 Aluminium 6082-T6

FIGURE 1 The double strap joint studied in this work.

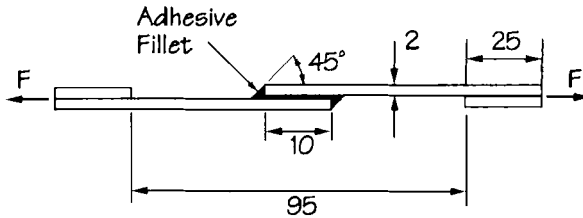

Dimensions in mm
 Bondline Thickness = 0.2mm
 Specimen Width = 25mm
 Aluminium: AA5251-H3

FIGURE 2 The single-lap joint studied in this work.

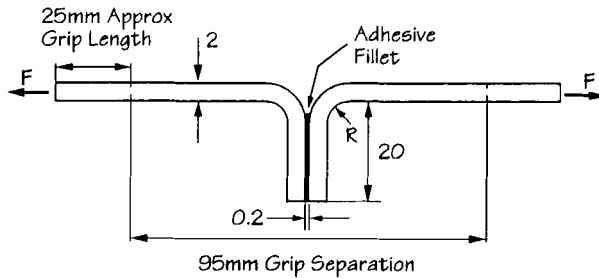

Dimensions in mm
 $R = 1.5 \times$ aluminium gauge
 Specimen Width = 25mm
 Aluminium: AA5754-O

FIGURE 3 The T-peel joint studied in this work.

Downloaded At: 13:32 22 January 2011

detailed examination of the stresses in the joints it has been possible to determine the failure criterion.

The literature on the stress analysis of adhesives is considerable, and spans some fifty-five years. The first analysis was performed by Volkersen,¹ who was actually interested in the analysis of the stresses experienced by a row of rivets in a lap joint. This problem was too difficult to solve in the pre-computer age. As an approximation, he solved the problem of a bonded lap joint, and qualitatively extrapolated the result to a riveted joint. The results of Volkersen's analysis showed that the shear stress in a bond is distributed non-uniformly, with sharp peaks at the ends of the bondline.

However, Volkersen's analysis did not allow for rotational effects within the joint. There are bending moments present, which cause the rotation shown in Figure 4. These moments were first analyzed by Goland and Reissner.² In fact, these authors made a minor algebraic error, which was not present in the similar analysis by Sneddon.³ In single-lap joints, the rotation effect shown in Figure 4 is well known; it is less well known that similar effects occur in double-lap joints. Tensile stresses were thus shown to be very important even in joints loaded in shear.

These authors all took a closed-form continuum approach to their analysis. This method has been taken to its limit by Hart-Smith, who has analyzed single-lap joints,⁴ scarf and stepped-lap joints,⁵ double-lap joints,⁶ and bonded composites.⁷ He takes full account of the various bending moments and, for the first time, of plasticity in the adhesive material. He does not account for through-thickness variation in the adhesive stresses, nor does he actually postulate a failure criterion. Rather, his very informative inferences on this subject are qualitative. This author reviews his own work in Reference 8.

The omissions made by Hart-Smith have been forced upon him by the closed-form approach. The only practical way to progress beyond these limits is by some form of numerical analysis. Although the boundary element method has been tried,⁹ the most appropriate numerical technique for this purpose is the finite element method.¹⁰ The most eminent exponent of such analysis is Adams who, with various co-workers, has published many papers on the subject, and one book.¹¹

The first major innovation of these authors was to include a spew fillet in their analysis.¹² This fillet consists of the adhesive squeezed out of the ends of joints as the

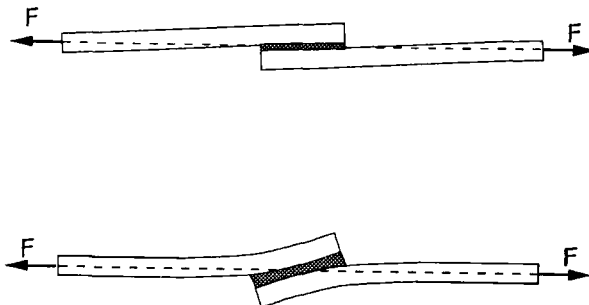

FIGURE 4 Local bending and rotation of a single-lap joint (exaggerated).

bond is made and is present in all joints; see, for example, Figure 2. The presence of this fillet radically alters the stress pattern at the ends of the bondline. The discovery of this fact was a major contribution to the subject.

These authors subsequently extended their work to include material non-linearity in the adhesive, pointing out that the yield criterion is that of Raghava *et al.*,¹³ rather than that of von Mises,¹⁴ and to include significant adherend yielding.^{15,16}

Another major innovation of this group was to consider variations in the stresses through the bondline thickness.¹⁷ In all this work, these authors assume that the bond fails when either a peak principal stress or a peak principal strain is reached at some point in the adhesive. In fact, their calculated values for these peaks cannot be reproduced and, if solved correctly (*i.e.* with adequately dense meshes), the models of Adams *et al.* up to 1981 predict that the peak stress is infinite.

Adams and Harris¹⁸ remove this singularity by radiusing the adherend corner encased in the spew fillet. The magnitude of the radius is then predicted to affect the value of the peak stresses found in the adhesive and, hence, the failure load. These authors find a peak in the strain energy density, and hence shear stress, slightly away from the interface. Clark¹⁹ finds a peak in the shear stress actually on the interface, using extremely detailed finite element models. Thus, while the work of the Adams school has not yet reached the stage of quantitative joint strength prediction, it has taught us much about the nature of stresses in bonded joints.

One other group of authors, Czarnocki and Piekarski,²⁰ claim to be able to predict lap joint failure by considering peak values of stresses in the adhesive. Whilst heavily influenced by the Adams school, these authors assume that the key parameter is the peak value of the strain energy density, not the principal stresses. Neither these authors nor Adams *et al.* extrapolate their predictions of failure from one joint geometry to any other.

Taking a rather different approach, Crocombe²¹ postulates that a lap joint fails when the adhesive has yielded right through the thickness of the joint. He is primarily interested in very ductile adhesives that show little or no work hardening. Neither assumption is valid for the rubber-toughened epoxy materials that are suitable for bonding vehicle structures. However, this is the first published suggestion that one should think in terms of failure over a zone rather than at a point. Crocombe is unable to make his failure criterion work in other than lap joints.

It is shown in the present work that these difficulties can be resolved by postulating that the ultimate tensile stress of the toughened epoxies examined must be exceeded over a finite zone. For these adhesive materials, it is then possible to predict the static strength of the bond in a variety of joint geometries.

For reasons of commercial confidentiality, the two adhesive materials examined will be referred to as adhesives A and B. The adhesives have been developed for *Alcan International Ltd.* as part of their Aluminium Vehicle Technology^{22,23} which aims towards the development of adhesively-bonded aluminium automotive structures.^{24,25} They are single-part epoxies with second-phase rubber toughening agents and brittle inorganic filler particles. These adhesives have been used by *Alcan* to bond 5000 and 6000 series aluminium alloys that have been pretreated with a proprietary pretreatment.

2. MODELLING OF BONDED JOINTS

Three different joint geometries were used for the validation of the new failure criterion. These included a double strap joint, single-lap joint and T-peel joint. The corresponding finite element models are shown in Figures 5 to 7. In each case, the finite element model was given the dimensions shown in Figures 1–3, respectively. Each of these models uses the ANSYS²⁶ finite element program, and requires non-linear material properties to be used. Special subroutines have also been added to versions 4.3 and 4.4 of ANSYS to incorporate the Raghava yield criterion. Although we have used very refined models in this work in order to study in great detail the development of the stresses in the adhesive, in practice models with a slightly less refined mesh may be used to predict the joint strength. Checks should be made to ensure that the mesh refinement is sufficient to produce adequate convergence of the analysis.

Each of the different joint models is now discussed, as well as the different approaches used for modelling the adhesive stress-strain curve. All failure strengths

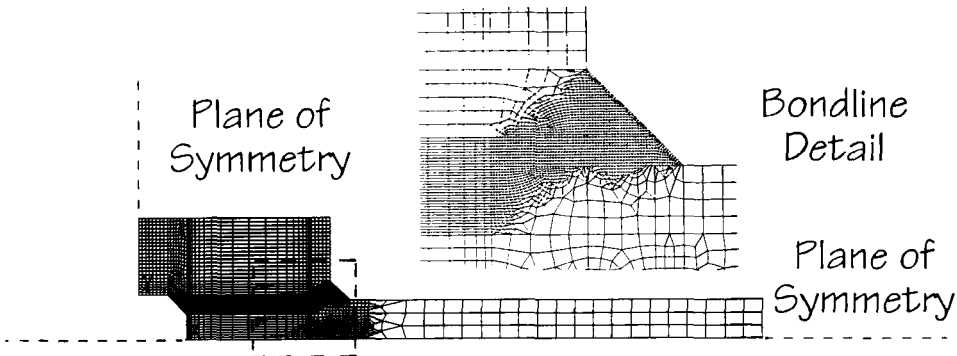

FIGURE 5 The finite element model of the double strap joint used in this work.

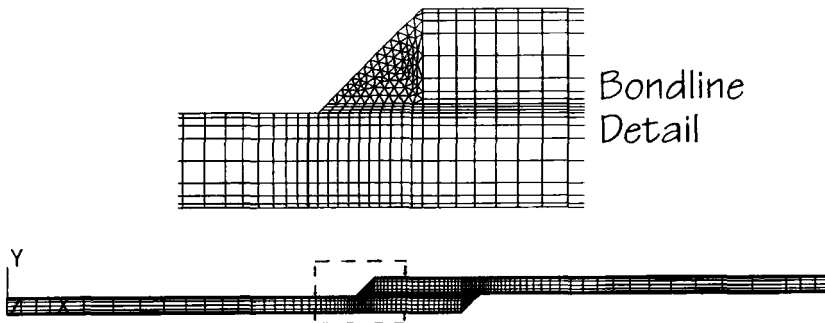

FIGURE 6 The finite element model of the single-lap joint used in this work.

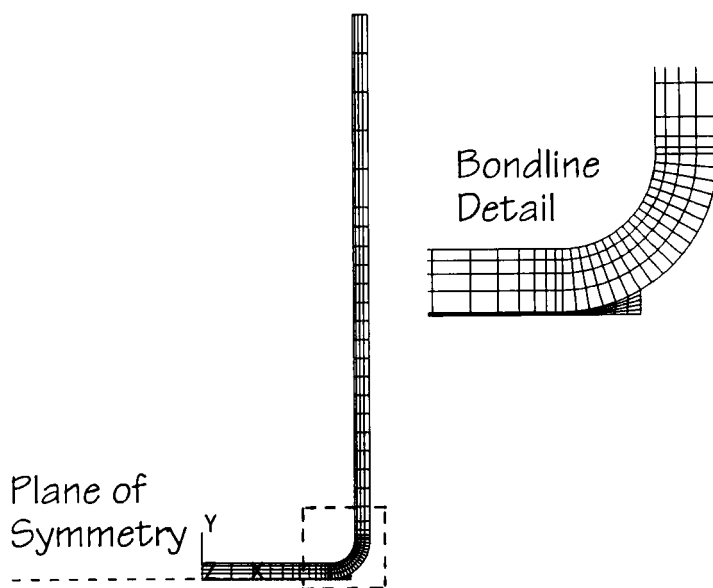

FIGURE 7 The finite element model of the T-peel joint used in this work.

will be quoted in N mm^{-1} , which is the force required to break a unit depth (normal to the plane modelled) of the joint. The strengths of the joints were measured by pulling them in a tensile testing machine at a cross-head speed of 2 mm min^{-1} .

2.1 Modelling of the Stress-Strain Curves of Adhesives

Figure 8 shows the modelled tensile stress-strain curves for the two adhesives used in this study. These properties were obtained from tensile tests of bulk adhesive specimens, using a standard tensile testing machine. The casting of the cylindrical adhesive test specimens required some care to avoid over-curing in the centre due to the large exotherm generated during cure. This was achieved by using a large metallic mould which was cooled during the casting. In the finite element analysis, both bi-linear and pentilinear fits were used in the modelling of these curves. As may be seen in Figure 8, the stress-strain curves of the adhesives were extended beyond the UTS to enable the finite element code to model the material response in the UTS zone. At present we have not investigated the influence of the way this extension is modelled on the predicted joint strength.

The use of the von Mises and the Raghava yield criteria has been investigated and is discussed in detail later. Non-linear properties of the aluminium were also included in the modelling, and typical engineering strength properties for the alloys used in the study are given in Table I.

An important aspect of the modelling of the adhesive in this work was that it was modelled in plane strain, with the aluminium adherends modelled in plane stress. The difference in the modulus of the aluminium, compared with the adhesive, re-

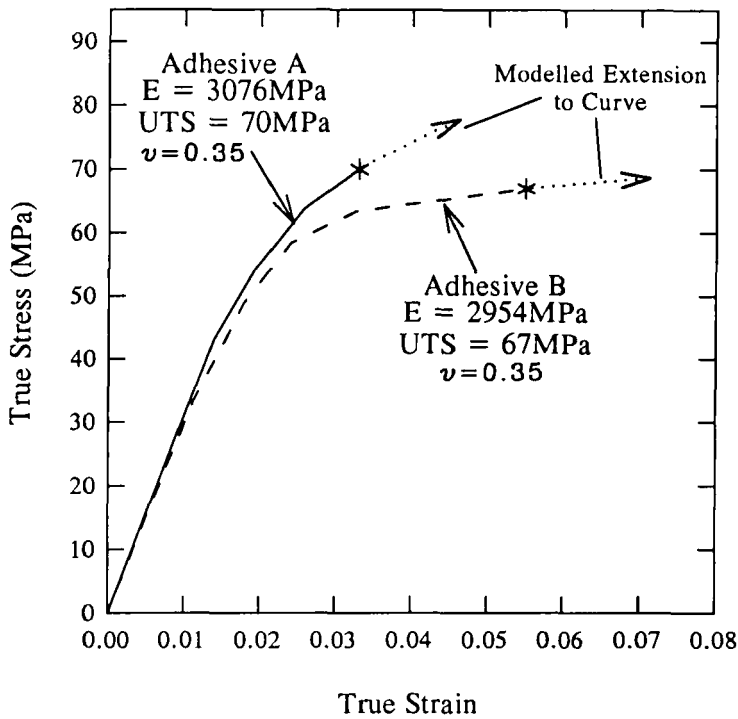

FIGURE 8 Modelled adhesive stress-strain curves.

TABLE I
Aluminium alloy mechanical properties

Material	Elastic modulus (MPa)	Poisson's ratio	0.2% Proof stress (MPa)	UTS (MPa)	Elongation (50 mm gauge)
AA5754-O	70000	0.33	100	220	23
AA5251-H3	70000	0.33	160	220	12
AA6082-T6	70000	0.33	240	295	8

sults in the adhesive being constrained in a triaxial state of stress. An approximate way to model this is to model the adhesive in plane strain.¹¹

2.2 Finite Element Models of Joints

Figure 5 shows the double strap joint model, which allows for a corner radius to be placed on the outer adherend. It will be shown that this radius does not affect the predicted failure load when using the new failure criterion, so that it need not be included in the single-lap joint model. The use of symmetry was employed in all the models to minimise the model size.

Figure 6 shows the single-lap joint model. The aluminium was modelled as AA5251-H3 material by using a pentilinear material representation. Large displacement analysis and stress stiffening were also included, due to the very localised bending which takes place at the ends of the overlap.

Figure 7 shows the T-peel joint model. The aluminium material in the forming radius of this joint was modelled with increased strength properties to simulate the work-hardening of the material during bending of the radius.

In assessing the accuracy of a failure criterion, the ability to predict the location of failure as well as the load at failure is important. It is also the case that a failure criterion which correctly captures the mechanisms responsible for failure will be independent of the geometry of the specimen. With these points in mind, therefore, it is appropriate to examine the predictive capability of the failure criterion that is currently the most commonly used for bonded joints—UTS at a point.

2.3 Ultimate-Tensile-Stress-at-a-Point as a Failure Criterion

As mentioned in the Introduction, there is evidence in the literature that the corner radius of the adherend embedded in the spew fillet affects the failure load of lap joints.¹⁸ Measurements of this radius in the double strap joints, shown in Figure 1, suggest that (a) this radius is not constant, and (b) its value lies between 3 and 15 microns. According to Adams and Harris (*op cit.*), the peak stress in the adhesive varies as the logarithm of the radius. We have found no corresponding variability in joint strength in our tests on this joint geometry. Therefore, a failure criterion for this joint should predict that this corner radius does not affect the failure load.

Single-lap joints may break as shown in Figure 9, leaving a tab of adhesive on the adjacent surface of the second adherend. The exact location of failure will depend on the amount of local bending of the adherends. If peak stress at a point is used as the failure criterion, failure is predicted to initiate at the adherend corner, as shown in Figure 10. This is not observed in the experimental results, which give a failure in the main body of the fillet as shown in Figure 9. Comparison of the UTS of adhesive A with the stresses in the joint shown in Figure 10 implies that, if the failure criterion is that the UTS must not be exceeded at any point in the adhesive,

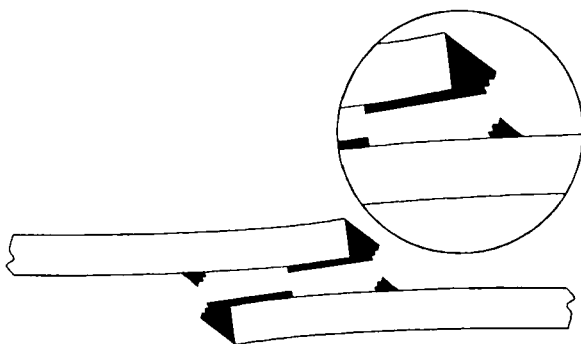

FIGURE 9 Typical failure mode of single-lap joints.

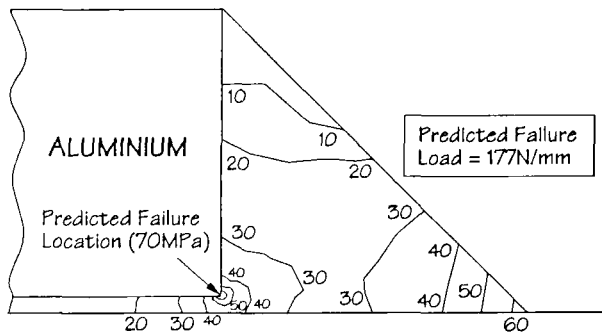

FIGURE 10 Maximum principal stresses in a single-lap joint.

the failure load predicted is 177 Nmm^{-1} , compared with the observed failure load of 320 Nmm^{-1} .

We have observed, therefore, that using the ultimate tensile stress at a point (a) predicts adherend corner radius effects that are not observed; (b) predicts the wrong locus of failure in single-lap joints; and (c) seriously under-predicts the failure load of single-lap joints.

Using the UTS-at-a-point criterion for adhesive A predicts a failure load of 500 Nmm^{-1} for a double strap joint with a 10 micron corner radius, compared with the experimentally-measured value of 740 Nmm^{-1} . We are forced to conclude that this failure criterion is profoundly inadequate.

3. A NEW FAILURE CRITERION: "ULTIMATE TENSILE STRESS OVER A ZONE"

In this section, the "UTS over a zone" failure criterion is discussed in detail, and a comparison made between the predicted and measured failure loads for several different joint geometries and two different adhesives. As will be demonstrated, the new failure criterion proposed is that the joint will fail if the maximum principal stress (σ_1) exceeds the ultimate tensile stress of the adhesive over a finite zone. The size of the zone is measured perpendicular to the maximum principal stress.

3.1 Determination of the Zone Size

The size of the UTS zone for an adhesive is obtained from a combination of experiment and analysis. Figure 11(a) shows the failure mode of a 5 mm overlap single-lap joint using adhesive B. The general geometry of the joint was as shown in Figure 2 with a 45° fillet. Finite element modelling of this joint, using the adhesive stress-strain curve in Figure 8, was conducted.

Figure 11(b) gives the predicted maximum principal stress distribution in the adhesive at the measured failure load of the specimen. The direction of the maximum principal stress is also given. In all the joints examined by us, the direction of the maximum principal stress varied only slightly in the region of interest. It was, there-

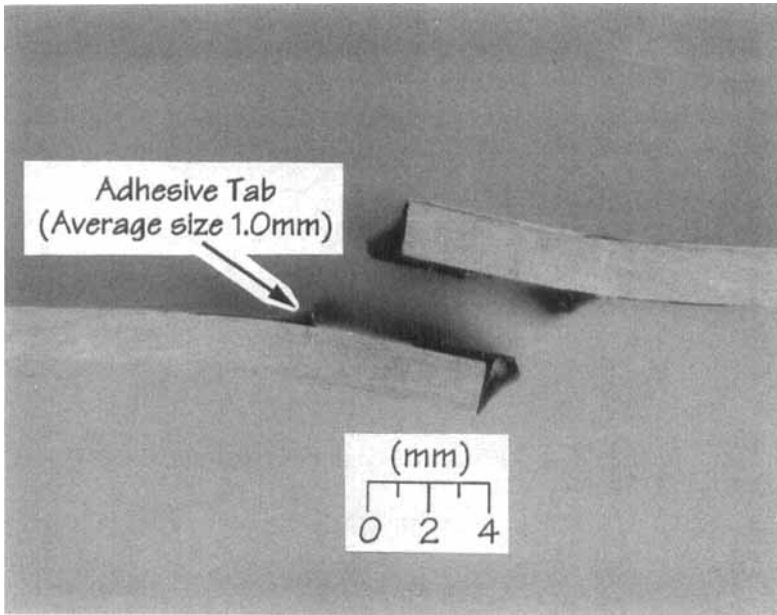

FIGURE 11(a) Failure mode of a single-lap joint (adhesive B).

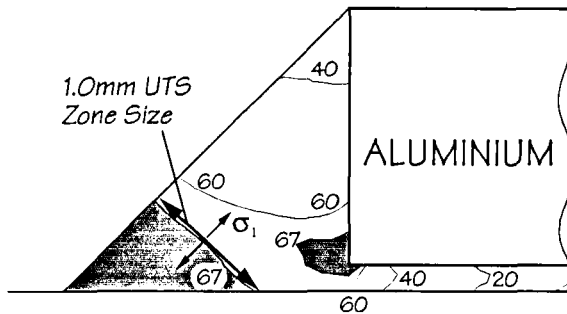

FIGURE 11(b) Predicted adhesive maximum principal stress (σ_1) distribution at the failure load of a single-lap joint.

fore, considered to be acceptable to average the direction of principal stress to determine the zone size. The zone of the adhesive with stresses above the adhesive UTS is shaded. Since it is postulated that the critical zone size should be measured perpendicular to the maximum principal stress, the predicted zone size for failure of adhesive B is 1.0 mm as obtained directly from Figure 11(b).

By comparing Figures 11(a) and 11(b), it is seen that the predicted location of failure using this new criterion is in very good agreement with the experimentally-

observed location. It was also found that the average size of the tab of adhesive left on the adherend of the test specimen was close to 1 mm. This provided very good evidence for the existence of a UTS zone and gave a very good correlation between predicted zone size and measured size.

From Figure 11(b) it may be seen that at the corner of the adherend a small second zone of adhesive is stressed above the UTS. This second zone generally grows at a much slower rate than the failure zone at the end of the fillet, where failure is predicted to occur eventually.

3.2 Prediction of Failure Using "UTS over a Zone Criterion"

In order to check the prediction of the static strength of single-lap joints using a zone size of 1.0 mm for adhesive B, a prediction of the strength of a 10 mm overlap joint was conducted and was within 5% of the experimentally-measured strength. The zone size was then used in the prediction of the strength of T-peel joints also bonded with adhesive B.

Figure 12(a) compares a failed T-peel joint in the area of the fillet with the predicted maximum principal stress distribution (Figure 12 (b)) using the 1.0 mm zone size. The correlation between the measured and predicted static strength is within 5.2%. It is clear from Figures 12(a) and (b) that the "UTS over a zone" criterion is able to predict the position of the region of the bondline in which failure occurs. In the T-peel joint in Figure 12(a), the crack location is seen to be in the front of the fillet, in the adhesive. From here it runs along the aluminium forming radius close to the interface into the bondline. The predicted location of failure using the "UTS over a zone" criterion is very close to the observed location.

These examples provide evidence of the capability of the "UTS over a zone" criterion to predict the location of failure for several different types of joint geometry. This is combined with a high accuracy in the prediction of the magnitude of the failure loads.

The "UTS over a zone" criterion has also been used with adhesive A. For this adhesive the UTS zone size was determined as 0.68 mm. Table II compares the predicted and the experimentally-measured values for the static strength of single-lap, double strap and T-peel joints. It is seen that the criterion is able to predict within 5% for all of the different joint geometries.

The influence of adherend radius on the strength of lap joints has been discussed previously. Although the use of a criterion based on stress at a point would suggest that the strength of lap joints is controlled by the size of the radius, experimental results suggest that this is not the case. However, using the new "UTS over a zone" criterion, it is shown in Figures 13(a) and (b) that the size of the UTS zone in a double strap joint is not influenced by the presence of a radius at the corner of the adherend. This would, therefore, correlate with the observed results from experiment and predict no influence of corner radius on the failure load of lap joints.

These results demonstrate the ability of the "UTS over a zone" failure criterion to address all of the problems associated with the use of a criterion based on stress at a point. The "UTS over a zone" criterion has been able to correctly predict the influence of adherend corner radius on the strength of lap joints, as well as to predict

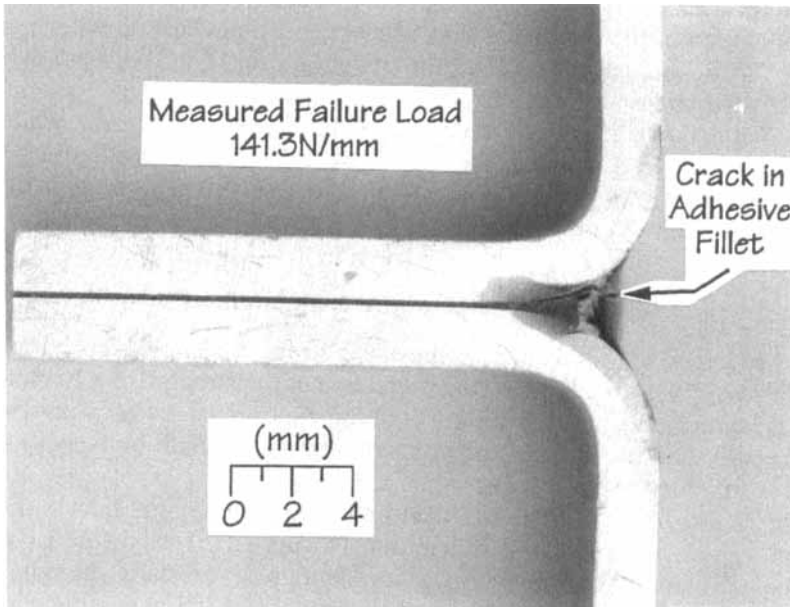

FIGURE 12 (a) Failure mode of T-peel joint (adhesive B).

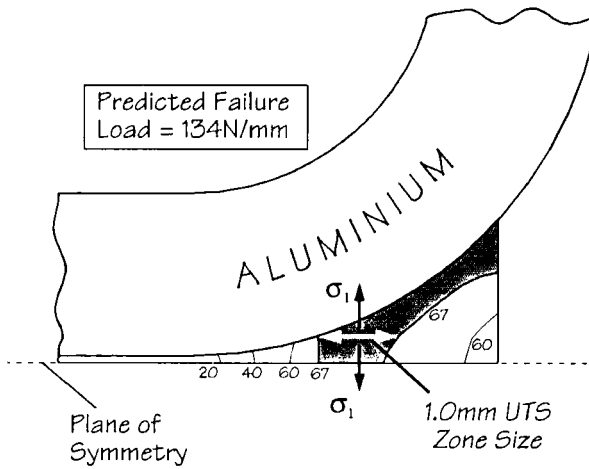

FIGURE 12(b) Predicted failure load and maximum principal stress (σ_1) distribution for the T-peel joint (adhesive B).

Downloaded At: 13:32 22 January 2011

TABLE II
Prediction of strength for various joint geometries
(Adhesive A)

Joint geometry	Joint strength (N/mm)	
	Prediction (0.68 mm zone)	Experimental value
Single-lap	Calibration	320
Double strap	701	740
T-peel	123.7	123

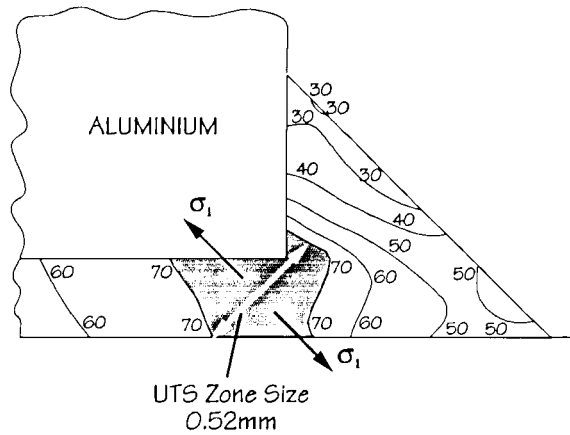

FIGURE 13(a) Zone size in partially-loaded double strap joint without corner radius.

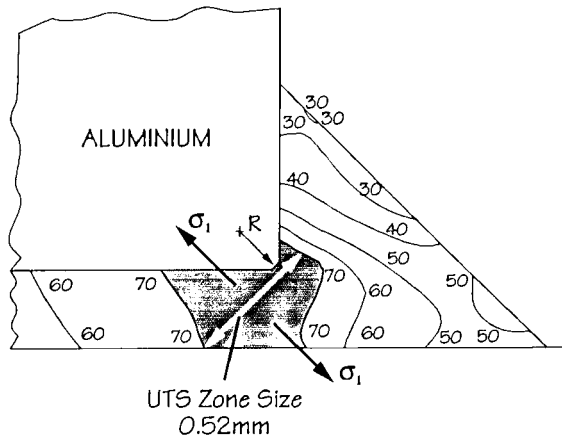

FIGURE 13(b) Zone size in double strap joint with 29 micron corner radius at same applied load as Figure 13(a).

accurately the location of failure and the magnitude of the failure load for a variety of joint geometries for two different adhesives.

3.3 Use of the New Criterion in Joint Design

This criterion has been used to investigate the influence of various manufacturing parameters as part of the development of a joint design procedure for bonded aluminium structures.^{27,28} In automotive structures, the most common form of joint is a peel joint, as a result of the requirement to obtain access to the flanges of the joints for spot-welding. This is also true of weld-bonded automotive structures where the spot-welds are used to hold the assembly together prior to final cure of the adhesive. It has been established that the size of the adhesive fillet is the most important parameter influencing the strength of T-peel joints.²⁷ The definition of fillet size in T-peel joints is explained in Figure 14. The size of the fillets in real joints is measured directly from a shadow graph image of the fillet region.

Figure 15 compares the predicted influence of the size of the adhesive fillet with the measured values for the static strength of bonded T-peel joints using adhesive B. The prediction of the failure load is compared for two different zone sizes and for a criterion based on UTS at a point. It is observed that the size of the zone has very little influence on the prediction at larger fillet sizes, but a very marked influence at smaller fillet sizes. Improved correlation is obtained at smaller fillet sizes with a larger zone size. This is important for design, since a small fillet will often be assumed for the purpose of producing a conservative prediction of joint strength.

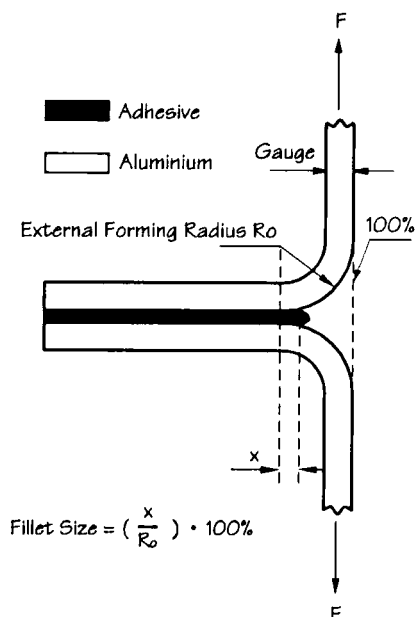

FIGURE 14 Definition of fillet size in a T-peel joint.

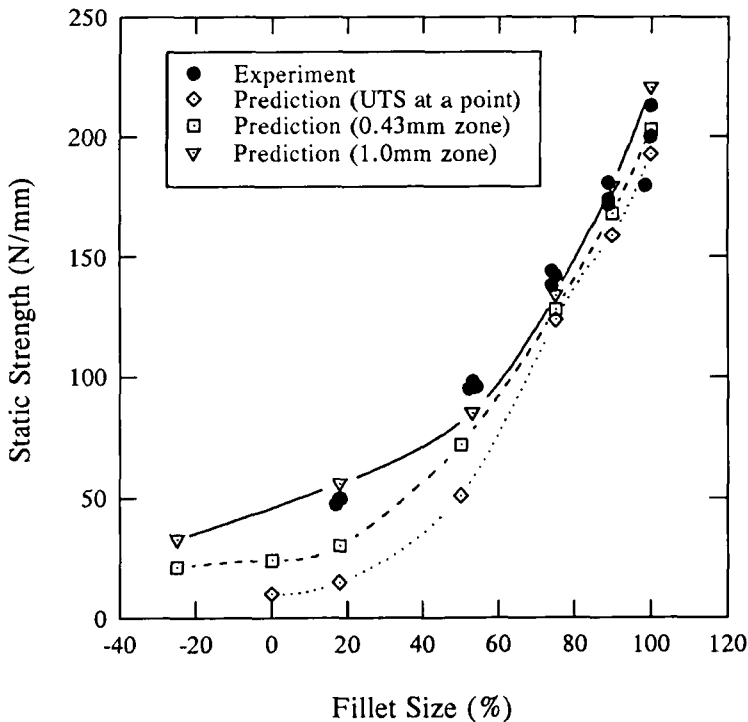

FIGURE 15 Prediction of the influence of fillet size on T-peel static strength (adhesive B).

Figure 15 shows that the 1.0 mm zone size determined for adhesive B gives a good correlation over the full range of fillet sizes. It is apparent, however, that using a criterion based on UTS at a point produces a significant under-prediction of strength for joints with small fillet sizes.

One design variable which is often determined from considerations other than joint strength, such as structural stiffness, is the gauge of the material to be joined. Figure 16 shows the correlation between the experimentally-measured influence of gauge on the static strength of T-peel joints and the predicted influence using a 1.0 mm zone size for adhesive B. It is seen that a good correlation between measured and predicted values is obtained. Figure 17 compares the predicted influence of forming radius on T-peel joint strength with the experimentally measured influence. Correlation within 15% is obtained with a slightly conservative prediction.

We have seen, therefore, that the "UTS over a zone" failure criterion is able to predict the influence of joint design parameters on joint strength to within 15% of the experimentally-measured values.

4. DISCUSSION

Various modelling fits to the adhesive stress-strain curve for adhesive A, shown in Figure 8, have been examined. The double strap joint model was used for the

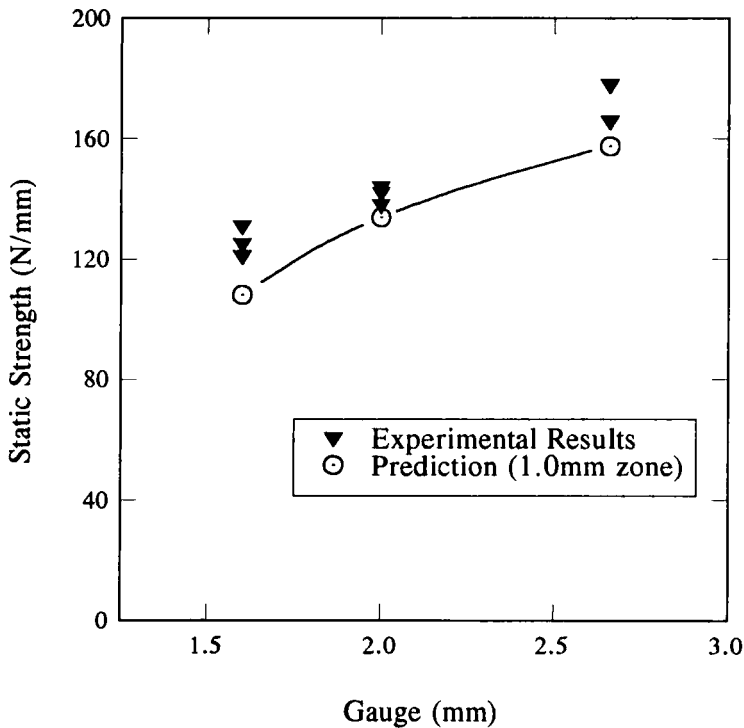

FIGURE 16 Prediction of influence of adherend gauge on T-peel static strength (adhesive B).

cases of: (a) pentilinear fit with von Mises' yield criterion; (b) bilinear fit with von Mises' yield criterion; and (c) bilinear fit with Raghava yield criterion. For the Raghava yield criterion the ratio of compressive to tensile yield stress was set at 1.2. In reality it is almost impossible to tell where reversible creep ends and irreversible yield begins in these materials, so that the value of the compressive-to-tensile yield stresses is unknown.

The results from the analyses showed that virtually the same UTS zone size was obtained whichever material fit and yield criterion was used. This suggested that the predicted failure load was not significantly dependent on the way in which the material was modelled. As already mentioned, however, the influence of the way in which the material curve is modelled beyond the UTS value has not been studied, and this is a topic for future research.

All the models used were two-dimensional. We have examined a fully three-dimensional model of a T-peel joint, and found that the approximation that the aluminium is in plane stress, but the adhesive is plane strain, gives very good correlation with a two-dimensional model, except in perhaps the 10% of the joint closest to the free edge. The characteristic length of the zone size postulated here is a linear length measured perpendicular to the maximum principal stress direction. Therefore, the criterion does not depend on predicting an area or volume, but is based on establishing a zone, with the major dimension at least equal to the UTS

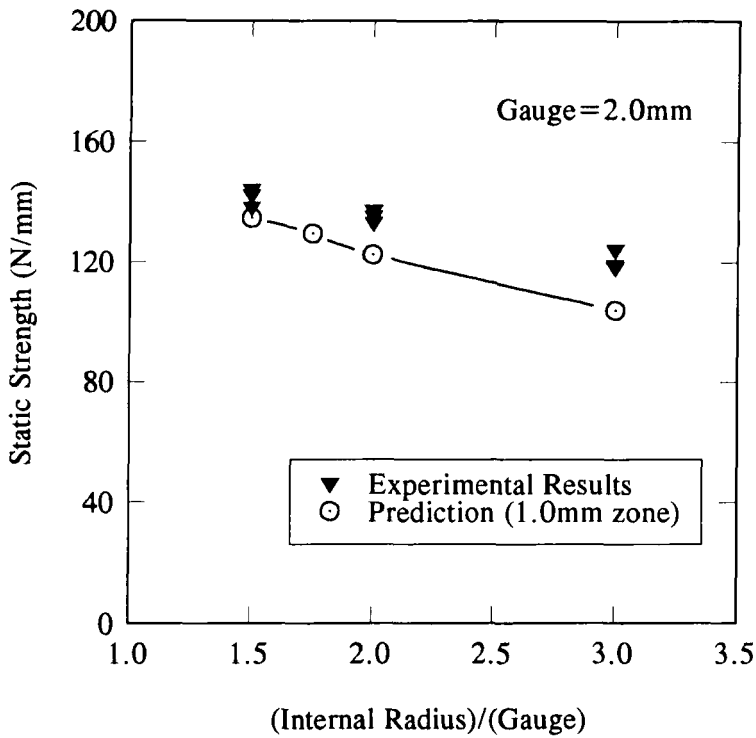

FIGURE 17 Prediction of influence of adherend forming radius on T-peel static strength (adhesive B).

zone size measured for the adhesive. We, therefore, regard two-dimensional models as an adequate approximation in the prediction of joint strengths.

The criterion cannot be determined from a uniform tensile specimen alone because, below the UTS of the adhesive, the UTS zone size is zero. At the UTS, the zone size is the same as the cross-section of the specimen, regardless of specimen size. Such a specimen tells us which stress to use, but not which zone size. It is no doubt possible to design a non-uniform tensile specimen, from which the UTS zone size could be determined by mathematical modelling. However, the practical difficulty of making cast epoxy specimens is such that it is easier to make bonded test joints.

The authors conjecture that the criterion proposed here could have a basis in fracture mechanics. However, one of the objectives of this work was to develop a failure criterion which would avoid the need to model cracks in adhesive joints. The problem of where to put cracks whose location is not known *a priori* is thus avoided. It would be interesting as a future study to compare the size of the UTS zone proposed here with the critical flaw size of the adhesive materials.

Although we have expressed our criterion based on stress, it would be interesting to consider a similar approach based on strain. This is also a topic for further research.

5. CONCLUSIONS

A failure criterion has been developed for adhesive joints bonded with single-part, filled, rubber-toughened epoxy adhesives. For the first time, this single criterion successfully predicts the failure load in widely differing joint geometries.

The criterion is that the maximum principal stress must exceed the ultimate tensile stress of the adhesive material over a finite zone. The size of this zone in the direction normal to the maximum principal stress is a property of the adhesive determined from analysis and test. This criterion predicts failure loads in different joint geometries to within typically 5% of the experimentally-measured strengths. When the criterion is used to predict the influence of joint design parameters on joint strength, the criterion predicted within 15% of the experimentally-measured values for a wide range of parameters from a large number of experimental tests.

The criterion also successfully predicts the locus of adhesive failure in a variety of very different joint geometries, and that the adherend corner radius in lap joints should not influence joint strength, as observed from experiment.

Although the strengths of the new criterion have been demonstrated, further work is desirable to establish the mechanism responsible for failure of the adhesive material.

Acknowledgements

The authors are grateful to J. S. Crompton and E. McAlpine for helpful discussions; to B. Lee and S. M. Buckley for assistance with experiments; and to Alcan International Ltd. for permission to publish this work.

References

1. O. Volkersen, *Luftfahrtforschung* **15**, 41 (1938).
2. M. Goland and E. Reissner, *J. Appl. Mech. Trans. ASME* **66**, A17 (1944).
3. I. N. Sneddon, "The Distribution of Stress in Adhesive Joints," in *Adhesion*, D. D. Eley, Ed., (Oxford, Clarendon Press, 1961).
4. L. J. Hart-Smith, "Adhesively Bonded Single-Lap Joints," *NASA CR-112236*, Langley Research Centre (1973).
5. L. J. Hart-Smith, "Adhesively Bonded Scarf and Stepped-Lap Joints," *NASA CR-112237*, Langley Research Centre (1973).
6. L. J. Hart-Smith, "Adhesively Bonded Double-Lap Joints," *NASA CR-112235*, Langley Research Centre (1973).
7. L. J. Hart-Smith, "Analysis and Design of Advanced Composite Bonded Joints," *NASA CR-2218*, Langley Research Centre (1974).
8. L. J. Hart-Smith, in *Developments in Adhesives-2*, A. J. Kinloch, Ed. (Applied Science Publishers, London, 1981), p. 1.
9. J. D. Clark, "Verification of Finite Element Stress Analysis of Adhesive Bonds," *Proc. Int. Conf. on Quality Assurance and Standards in Finite Element Analysis*, Brighton, UK, May 1987 (National Engineering Laboratory, Glasgow, 1987).
10. K. J. Bathe, *Finite Element Procedures in Engineering Analysis*, (Prentice-Hall, Englewood Cliffs, N.J., 1982).
11. R. D. Adams and W. C. Wake, *Structural Adhesive Joints in Engineering*, (Elsevier Applied Science Publishers, London, 1984).
12. R. D. Adams and N. A. Peppiatt, *J. Strain Anal.* **9**, 185 (1974).
13. R. S. Raghava, R. M. Caddell and G. S. Y. Yeh, *J. Mat. Sci.* **8**, 225 (1973).
14. R. D. Adams, J. Coppedale and N. A. Peppiatt, in *Adhesion 2*, K. W. Allen, Ed. (Applied Science Publishers, London, 1978), p. 105.

15. J. A. Harris and R. D. Adams, *Int. Symp. on Adhesive Joints*, Kansas City, Proc. Org. Coatings and Plastics Div., (184 Natl. Amer. Chem. Soc.), p. 243 (1982).
16. J. A. Harris and R. D. Adams, in *Adhesion 8*, K. W. Allen, Ed. (Applied Science Publishers, London, 1983), p. 1.
17. A. D. Crocombe and R. D. Adams, *J. Adhesion* **13**, 141 (1981).
18. R. D. Adams and J. A. Harris, "The Influence of Local Geometry on the Strength of Adhesive Joints," *Int. J. Adhesion and Adhesives* **7**, 69 (1987).
19. J. D. Clark, "How to do Nonlinear Submodelling with Ansys," *Proc. 1989 Ansys Conference*, Pittsburgh, Penn., (Swanson Analysis Systems Inc., Houston, Penn., 1989), pp. 10–11.
20. P. Czarnocki and K. Piekarski, *Int. J. Adhesion and Adhesives* **6**, 93 (1986).
21. A. D. Crocombe, "Global Yielding as a Failure Criterion for Bonded Joints," *Int. J. Adhesion and Adhesives* **9**, 145 (1989).
22. M. J. Wheeler, P. G. Sheasby and D. Kewley, "Aluminium Structured Vehicle Technology—A Comprehensive Approach to Vehicle Design and Manufacturing in Aluminium," *SAE Technical Paper Series*, 870416 (1987).
23. W. F. Marwick and P. G. Sheasby, "Evaluation of Adhesives for Aluminium Structured Vehicles," *SAE Technical Paper Series*, 870151 (1987).
24. D. Nardini and A. Seeds, "Structural Design Considerations for Bonded Aluminium Structured Vehicles," *SAE Technical Paper Series*, 890716 (1989).
25. A. S. Warren, J. E. Wheatley, W. F. Marwick and D. J. Meadows, "The Building and Test-Track Evaluation of an Aluminium Structured Bertone X1/9 Replica Vehicle," *SAE Technical Paper Series*, 890718 (1989).
26. G. J. DeSalvo and R. W. Gorman, *Ansys Version 4.4 Users' Manual*, (Swanson Analysis Systems, Inc., Houston, Penn., 1989).
27. I. J. McGregor, D. Nardini, Y. Gao and D. J. Meadows, "The Development of a Joint Design Approach for Aluminium Automotive Structures," *SAE Technical Paper Series*, 922112 (1992).
28. I. J. McGregor, D. Nardini, Y. Gao and D. J. Meadows, "The Development of a Joint Design Procedure for Aluminium Automotive Structures," *Proc. Structural Adhesives in Engineering III*, (Plastics & Rubber Institute, London, 1992).